

COMPANY
WITH QUALITY SYSTEM
CERTIFIED BY DNV
ISO 9001

ECP 34

MECCALTE spa - Via Roma, 20 - 36051 CREAZZO (VI) ITALIA
Tel. 0444/396111 - Fax 0444/396166 - e-mail : mecc-alte-spa@meccalte.it
web site: www.meccalte.com

4 POLE

CARATTERISTICHE / CHARACTERISTICS / CARACTERISTIQUES / TECHNISCHE MERKMALE / CARACTERISTICAS

INDUSTRIAL RATINGS

ambient 40° C

Type	KVA - cos φ 0.8 - 3 Phase continuous							RENDIMENTI - EFFICIENCY - RENDEMENT WIRKUNGSGRAD - RENDIMIENTOS		
	CL. H (ΔT= 125°C)				CL. F (ΔT= 105°C)			η % CL. H (ΔT= 125°C)		
Series Star Y	380	400	415	IP45 400 V	380	400	415	2/4	3/4	4/4
Parallel Star YY	190	200	208		190	200	208			
Series Delta Δ	220	230	240		220	230	240			
Parallel Delta ΔΔ	110	115	120		110	115	120			
ECP 34 1S	85	85	85	65	77	77	77	90	91,9	91,5
ECP 34 2S	105	105	105	85	95	95	95	90,7	92,5	92,2
ECP 34 1L	130	130	130	104	118	118	118	91,5	93,2	92,7
ECP 34 2L	150	150	150	120	136	136	136	92	93,5	93,2

60 Hz	CL. H (ΔT= 125°C)				CL. F (ΔT= 105°C)			RENDIMENTI - EFFICIENCY - RENDEMENT WIRKUNGSGRAD - RENDIMIENTOS		
								η % CL. H (ΔT= 125°C)		
Series Star Y	440	460	480	IP45 480 V	440	460	480	2/4	3/4	4/4
Parallel Star YY	220	230	240		220	230	240			
Series Delta Δ	254	265	277		254	265	277			
Parallel Delta ΔΔ	127	133	138		127	133	138			
ECP 34 1S	102	102	102	78	92	92	92	91,8	93,8	93,4
ECP 34 2S	126	126	126	102	114	114	114	92,3	94,1	93,8
ECP 34 1L	145	156	156	125	130	141	141	93,3	94,9	94,4
ECP 34 2L	170	180	180	144	150	163	163	93,8	95,2	95

MARINE RATINGS ΔT = 90°C

ambient 45° C

Type	50 Hz 3 Phase continuous						60 Hz 3 Phase continuous					
	KVA - cos φ 0.8			RENDIMENTI - EFFICIENCY - RENDEMENT WIRKUNGSGRAD - RENDIMIENTOS η %			KVA - cos φ 0.8			RENDIMENTI - EFFICIENCY - RENDEMENT WIRKUNGSGRAD - RENDIMIENTOS η %		
Series Star Y	380	400	415	2/4	3/4	4/4	440	460	480	2/4	3/4	4/4
Parallel Star YY	190	200	208				220	230	240			
Series Delta Δ	220	230	240				254	265	277			
Parallel Delta ΔΔ	110	115	120				127	133	138			
ECP 34 1S	72	72	72	89,3	91,2	91,9	86	86	86	91,1	93	96,8
ECP 34 2S	88	88	88	90	91,8	92,5	106	106	106	91,6	93,4	94,1
ECP 34 1L	110	110	110	90,9	92,7	93,2	126	132	132	92,5	94,4	94,9
ECP 34 2L	126	126	126	91,4	92,9	93,5	145	151	151	93,3	94,6	95,2

Type	J (Kgm ²) B3-B14 FORM	Peso/Weight Poids/Gewicht MD35 (Kg)	Vol. d'aria/Air Vol./Vol. d'air Luftmenge/Vol. de aire		Rumore - Noise - Bruit - Geräusch - Ruido dB(A)			
			50 Hz (m ³ /min)	60 Hz (m ³ /min)	50 Hz		60 Hz	
					1m	7m	1m	7m
ECP 34 1S	0,7663	341	19,3	23	79	65	83	69
ECP 34 2S	0,9415	419						
ECP 34 1L	1,0313	445						
ECP 34 2L	1,1863	491						

Dati di targa / Rating / Données pour plaque
Angaben auf dem Schild / Características nominales



**DATI ELETTRICI TIPICI / TYPICAL ELECTRICAL DATA / DONNEES ELECTRIQUES
TYPISCHE ELEKTRISCHE DATEN / DATOS GENERALES ELECTRICOS**

TIPO / TYPE / TYPE / TYP / TIPO		ECP 34 1S	ECP 34 2S	ECP 34 1L	ECP 34 2L
Potenza classe "F" / Rating "F" class Puissance class "F" / Leistung klasse "F" Potencia clase "F"	kVA 50 Hz	77	95	118	136
	kVA 60 Hz	92	114	141	163
Reattanza sincrona diretta / Direct - axis synchronous reactance / Reactance longitudinale synchrone / Direkte Synchronreaktanz / Reactancia sincrónica directa	X _d %	325	230	214	240
Reattanza transitoria diretta / Direct - axis transient reactance / Reactance longitudinale transitoire / Direkte vorübergehende Reaktanz / Reactancia transitoria directa	X' _d %	22,3	17,6	17,2	14,8
Reattanza subtransitoria diretta / Direct - axis subtransient reactance / Reactance longitudinale subtransitoire / Direkte momentane Reaktanz / Reactancia subtransitoria directa	X'' _d %	7,4	5,7	6,8	6,2
Reattanza sincrona in quadratura diretta / Quadrature - axis synchronous reactance / Reactance transversale synchrone / Um 90° verschobene Synchronreaktanze / Reactancia sincrónica en cuadratura	X _q %	170,5	149,6	147,6	122,1
Reattanza transitoria in quadratura / Quadrature - axis transient reactance / Reactance transversale transitoire / Um 90° verschoben vorübergehende Reaktanz / Reactancia transitoria en cuadratura	X' _q %	170,5	149,6	147,6	122,1
Reattanza subtransitoria in quadratura / Quadrature - axis subtransient reactance / Reactance transversale subtransitoire / Um 90° verschoben momentane Reaktanz / Reactancia subtransitoria en cuadratura	X'' _q %	29,5	31,2	29,9	26,5
Reattanza di sequenza inversa / Negative - sequence reactance / Reactance inverse / Gegenerreaktanz / Reactancia de sequencia inversa	X ₂ %	19,2	18,5	18,5	16,5
Reattanza di sequenza zero / Zero sequence reactance / Reactance homopolaire / Null - Phasenfolge Reaktanz / Reactancia de secuencia cero	X ₀ %	3,6	3,5	2,9	2,5
Costante di tempo transitoria / Transient time constant / Constante de temps transitoire / Vorübergehende Zeitkonstante / Constante de tiempo transitoria	T' _d (ms)	41,92	39,3	37,2	40,1
Costante di tempo subtransitoria / Subtransient time constant / Constante de temps subtransitoire / Momentane Zeitkonstante / Constante de tiempo subtransitoria	T'' _d (ms)	5,75	5,5	7,6	9,5
Costante di tempo unidirezionale / Armature time constant / Constante de temps d'armature / Einseitig gerichtete Zeitkonstante / Constante de tiempo unidireccional	T _α (ms)	15,4	14,6	16,3	17
Costante di tempo a vuoto / Open circuit time constant / Constante de temps transitoire à vide / Leerlauf - Zeitkonstante / Constante de tiempo en vacio	T' _{do} (s)	1,5	1,7	1,8	1,9
Rapporto di cortocircuito / Short - circuit ratio / Rapport de court circuit / Kurzschlussverhältnis / Relación de cortocircuito	K _{cc}	0,5	0,47	0,49	0,48
Resistenza di avvolgimento statore / Stator winding resistance / Résistance de bobinage du stator / Wicklungswiderstand / Resistencia de bobinado estator	Ω 1 - 2 20 °C	0,03	0,02	0,018	0,015

REGULATOR		PARALLEL DEVICE	THERMAL PROTECTION			HEATERS	MECHANICAL PROTECTION			
SR7/2	UVR6		PTC	BIMET DEVICE.	PT100		IP21	IP23	IP45	IP55
●	□	□	□	□	□	□	●	□	□	□

● = Standard

□ = Optional

**DIMENSIONI D'INGOMBRO / OVERALL DIMENSIONS / ENCOMBREMENT / BAUMASSE / DIMENSIONES MAXIMAS
FORMA B3 - B14 / B3 - B14 FORM / FORME B3 - B14 / FORM B3 - B14 / FORMA B3 - B14**

dimensions in mm

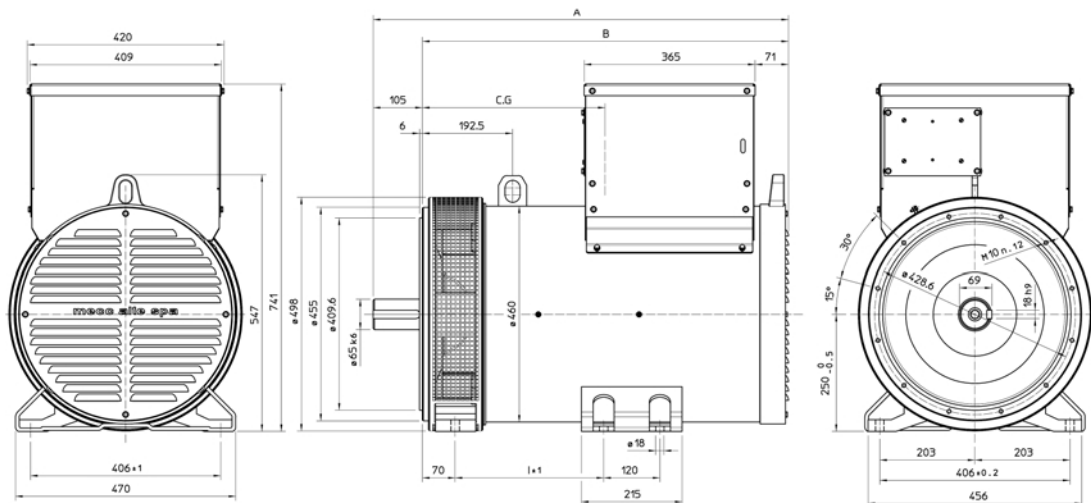

TIPO / TYPE/TYP	C.G
ECP 34 - 1S	310
ECP 34 - 2S	350
ECP 34 - 1L	365
ECP 34 - 2L	390

TIPO/TYPE/TYP	A	B	I
ECP 34 S	806,5	701,5	227
ECP 34 L	886,5	781,5	317

**DIMENSIONI D'INGOMBRO / OVERALL DIMENSIONS / ENCOMBREMENT / BAUMASSE / DIMENSIONES MAXIMAS
FORMA MD35 / MD35 FORM / FORME MD35 / FORM MD35 / FORMA MD35**

mensions in mm

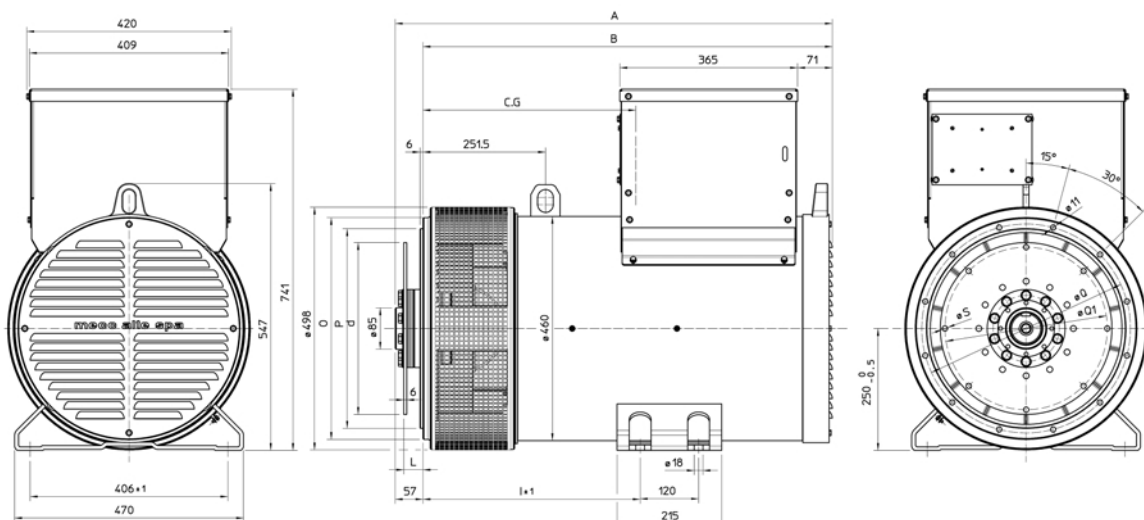

TIPO/TYPE/TYP	A	B	I
ECP 34 S	817,5	760,5	356
ECP 34 L	897,5	840,5	446

SAE N.	GIUNTI A DISCHI DISC COUPLING DISQUE DE MONOPALIER SCHEIBENKUPPLUNG				
	L	d	Q1	n. fori	S
10	53,8	314,32	295,27	8	11
11 1/2	39,6	352,42	333,37	8	11
14	25,4	466,72	438,15	8	14

SAE N.	FLANGIA - FLANGE BRIDE - FLANSCH			
	O	P	Q	n. fori
3	451	409,6	428,6	12
2	489	447,7	466,7	12
1	552	511,2	530,2	12

TIPO / TYPE/TYP	C.G
ECP 34 - 1S	358
ECP 34 - 2S	398
ECP 34 - 1L	415
ECP 34 - 2L	440

**ALTERNATORE SERIE ECP 34 - ELENCO PARTI DI RICAMBIO / ALTERNATOR SERIES ECP 34 - LIST OF SPARE PARTS
ALTERNATEUR SERIE ECP 34 - LISTE DES PIECES DETACHEES / GENERATOR SERIE ECP 34 - ERSATZTEILLISTE
ALTERNADOR SERIE ECP 34 - LISTA PARTES DE REPUESTO**

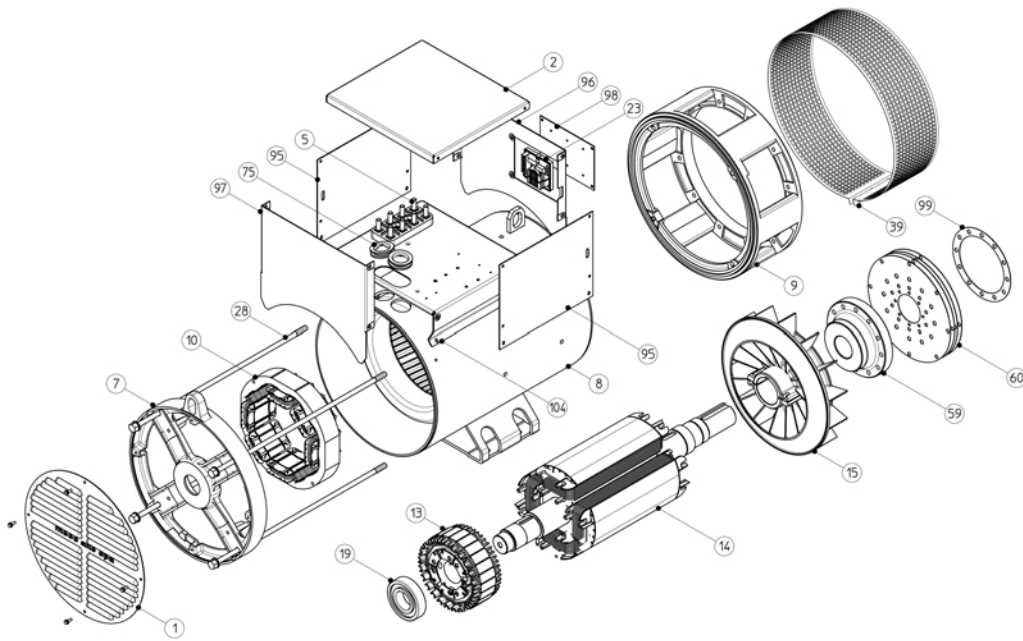

N.	DENOMINAZIONE	NAME	DESIGNATION	NAMEN	DENOMINACION	CODICE/CODE
1	chiusura posteriore	rear seal	tole de fermeture arriere	hinterer deckel	cierre posterior	9903905706
2	cuffia	terminal box lid	couvercle	klemmenkastendecker	tapa	9903905710
5	morsettiera di utilizz. m 12	users terminal board m 12	blanchette à bornes m 12	klemmenbrett m 12	placa bornes terminal m 12	9909915136
7	coperchio posteriore	non drive end bracket	flasque arriere	hinterer gehäuse	tapa posterior	6102306050
8	carcassa con statore	frame and stator	carcasse avec stator	gehäuse mit stator	carcaza con estator	3501587* **
9A	coperchio anteriore MD 35 SAE 1	drive end bracket SAE 1	flasque avant SAE 1	vorderer gehäuse SAE 1	tapa anterior SAE 1	6102312096
9B	coperchio anteriore MD 35 SAE 2	drive end bracket SAE 2	flasque avant SAE 2	vorderer gehäuse SAE 2	tapa anterior SAE 2	6102312095
9C	coperchio anteriore MD 35 SAE 3	drive end bracket SAE 3	flasque avant SAE 2	vorderer gehäuse SAE 3	tapa anterior SAE 3	6102312094
9D	coperchio anteriore B3/B14	drive end bracket B3/B14	flasque avant B3/B14	vorderer gehäuse B3/B14	tapa anterior B3/B14	6102312093
10	statore eccitatrice	exciter stator	stator excitatrice	erregerstator	estator excitatriz	4500481655
13	rotore eccitatrice	rotating inductor	exciter armature	erregerranker	inducido excitatriz	4500568212
14	induttore rotante	rotor assy	roue polaire	rotor	inducido rotante	2001052* **
15	ventola	fan	ventilateur	lüfterrad	ventilador	6102217252
17	cuscinetto anter.6314-2RS	front bearing 6314-2RS	roulement avant 6314-2RS	vorderes lager 6314-2RS	cojinete anterior 6314-2RS	9900905135
19	cuscinetto poster.6311-2RS	rear bearing 6311-2RS	roulement arrire 6311-2RS	hinter lager 6311-2RS	cojinete posterior 6311-2RS	9900905125
23	regolatore elettronico SR7	SR7 electronic regulator	regulateur electronique SR7	SR7 elektronischer regler	regulador electronico SR7	4505005091
28A	tirante coperchi S	cover stay bolt S	tige de flasque S	stehbolzen S	tirante de la tapa S	9911190423
28B	tirante coperchi L	cover stay bolt L	tige de flasque L	stehbolzen L	tirante de la tapa L	9911190424
39A	retina di protez. monosupp.	protection screen MD35	grille de protec. monop. a disq.	schutzgitter form MD35	rejilla de proteccion forma MD35	8500626225
39B	retina protezione bisupporto dx	protection screen B3/B14 dx	grille de protection B3/B14 forme dx	schutzgitter form B3/B14 dx	rejilla proteccion forma B3/B14 dx	8500626215
39C	retina protezione bisupporto sx	protection screen B3/B14 sx	grille de protection B3/B14 forme sx	schutzgitter form B3/B14 sx	rejilla proteccion forma B3/B14 sx	8500626220
59	mozzo portadis. volano 10-11-14	coupling hub flywheel 10-11-14	manch.porte disq. mouch. 10-11-14	nabe fliegen 10-11-14	cubo portadiscos moscas 10-11-14	5504012523
60A	dischi SAE 10	disc plates SAE 10	disques SAE 10	kupplugsscheiben SAE 10	discos SAE 10	6110611021
60B	dischi SAE 11	disc plates SAE 11	disques SAE 11	kupplugsscheiben SAE 11	discos SAE 11	6110611026
60C	dischi SAE 14	disc plates SAE 14	disques SAE 14	kupplugsscheiben SAE 14	discos SAE 14	6110611036
75	gommino passacavo	cable grommet	pass cable en caoufchoul	gummi auge	goma pasacables	9909509045
95	pannelli later.scat.mors.	termin.brd.side panels	panneaux lateraux b.a.b.	seitenbleche klemmenkasten	panel lateral caja de bornes	9903905709
96	pannello anter.scat.mors.	termin.brd.front panel	panneau avant b.a.b.	vorderes blech klemmkasten	panel anterior caja de bornes	9903905711
97	pannello post.scat.mors.	termin.brd.rear panel	panneau arriere b.a.b.	seitenbleche klemmkasten	panel posterior caja de bornes	9903905712
98	pannello porta regolatore	regulator holding panel	panneau blocage disques	deffnungsblech fuer regler	panel portaregolator	9903905716
99	anello bloccaggio dischi	disc locking ring	anneau locage des disques	spannring distanzscheiben	anillo de bloc.discos separadores	6110611505
104	pannello porta componenti	component-carrying panel	panneau support composant	komponentenblechtafel	panel porta componentes	7500620502

N.B. - Nella richiesta di pezzi di ricambio specificare il tipo e il codice dell'alternatore.

When requesting spare parts always indicate the alternator's type and code.

Pour toute demande de pièces detachees, priere de mentionner le type et le code de l'alternateur.

Bei Ersatzteilbestellung bitte immer die Teilbenennung den Typ und den code des Wechselstromgenerators angeben.

En cada pedido de piezas de recambio especificar siembre el tipo y el codigo del alternador.