

# 1100 Series 1106A-70TAG4

200 kVA Prime Power / 220 kVA Standby Power

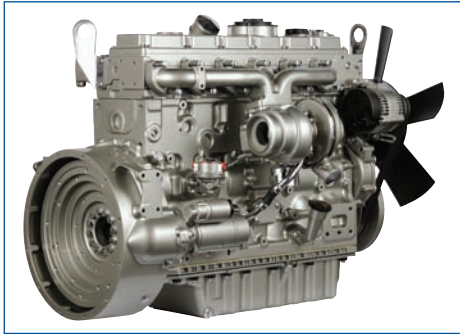

## Dependable power

- The Perkins 1106A-70TAG delivers up to 220 kVA standby at both 50 and 60Hz, providing greater productivity through an improved power to weight ratio.
- This world-class power density has been achieved in a 7 litre engine, using a mechanical fuel injection system; making this engine robust for all markets, with the ability to cope with the variation of fuel qualities around the world.

The 1106A has been designed for excellent load acceptance to ensure your facility is powered quickly at all conditions.

## Low operating costs

- Service intervals are set at 500 hours as standard
- Perkins provides comprehensive warranty cover for two years (up to 3,000 hours), with three years on major engine components.
- A low usage warranty package is also available.

## Flexibility

- The 1106A range has been designed to hit all the main power nodes and is easily switchable to 50/60Hz, perfect for rental business or to help reduce your engine inventory.

## World class product support

- Through an experienced global network of distributors and dealers, fully trained engine experts deliver total service support around the clock, 365 days a year. They have a comprehensive suite of web based tools at their finger tips, covering technical information, parts identification and ordering systems, all dedicated to maximising the productivity of your engine.
- Perkins actively pursues product support excellence by insisting our distribution network invest in their territory to provide you with a consistent quality of support across the globe.
- Throughout the entire life of a Perkins engine, we provide access to genuine OE specification parts giving 100% reassurance that you receive the very best in terms of quality for lowest possible cost... wherever your Perkins powered machine is operating in the world.

Building upon Perkins proven reputation within the power generation industry, the 1100 Series range of ElectropaK engines now fit even closer to customers needs.

In the world of power generation success is only gained by providing more for less. With the 1106A-70TAG Perkins has engineered even higher levels of reliability, yet lowered the cost of ownership.

1100A units are designed for territories that do not require compliance to EPA or EU emissions legislation. These engines are assembled around optimal, efficient manufacturing processes with state-of-the-art technology. They are built to provide the exact power solution for customers who sell their applications into lesser regulated countries.

Focusing on our common platform theme, changes to engine envelope dimensions and connection points have been kept to a minimum.

Engine Speed (rev/min)	Operation Type	Typical Generator Output (Net)		Engine Power			
		kVA	kWe	Gross		Net	
				kW	bhp	kW	bhp
1500	Prime Power	200	160	178.9	240	173.9	240
	Standby (maximum)	220	176	196.3	263	191.3	256
1800	Prime Power	200	160	179.2	240	171.2	229
	Standby (maximum)	219	175	198.2	266	190.2	255

# 1100 Series

## 1106A-70TAG4

200 kVA Prime Power / 220 kVA Standby Power

### Engine Specification

- Tropical radiator pipes and guards
- Flywheel housing
- Flywheel and starter ring
- Oil filters
- Starter motor
- Air cleaners and brackets
- Lubricating oil sump
- Alternator
- Induction manifolds
- Exhaust manifolds
- Fuel filter
- Cold start aid
- Engine mountings

### Engine Data

Number of cylinders ..... Vertical in-line 6 cylinder  
Bore and stroke ..... 105 x 135 mm (4.13 x 5.31 in)  
Displacement ..... 7.01 litres (428 in<sup>3</sup>)  
Aspiration ..... Turbocharged aftercooled  
Cycle ..... 4 stroke  
Combustion system ..... Direct injection  
Compression ratio ..... 16:1  
Engine rotation ..... Anti-clockwise viewed on flywheel  
Cooling system ..... Liquid  
Total lubrication capacity ..... 16.5 litres (4.36 US gal)  
Total coolant capacity ..... 21 litres (5.5 US gal)  
Dimensions  
Length ..... 1763 mm (69.4 in) with air cleaner  
Width ..... 756 mm (29.8 in)  
Height ..... 1142 mm (45 in)  
Dry weight ..... 788 kg (1737 lbs)

Final weight and dimensions will depend on completed specification.

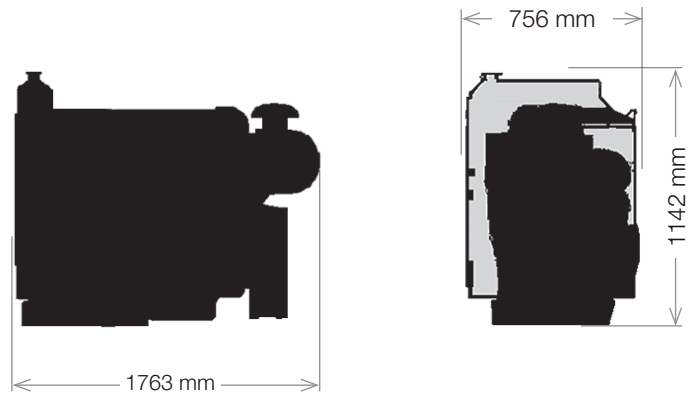

### Perkins Engines Company Limited

Peterborough PE1 5NA  
United Kingdom  
Telephone +44 (0)1733 583000  
Fax +44 (0)1733 582240

[www.perkins.com](http://www.perkins.com)

Distributed by: